

# VIBRATION MOUNTS: EVOLO® SERIES

EVOLO® 631: GRADE A-F



## APPLICATION

Optimum vibration isolation for a wide range of applications.

For larger equipment with high weights that need optimal vibration isolation at high and low frequencies. E.g. for generator sets, pump units, large diesel engines, compressor/cooling units, gear boxes, windmills, deckhouse-mountings, control cabins.

## TECHNICAL DATA

Article No. without height adjustment	Grade	Maximum load
1030631A0	A	60 kN
1030631B0	B	50 kN
1030631C0	C	40 kN
1030631D0	D	33 kN
1030631E0	E	23 kN
1030631F0	F	17 kN

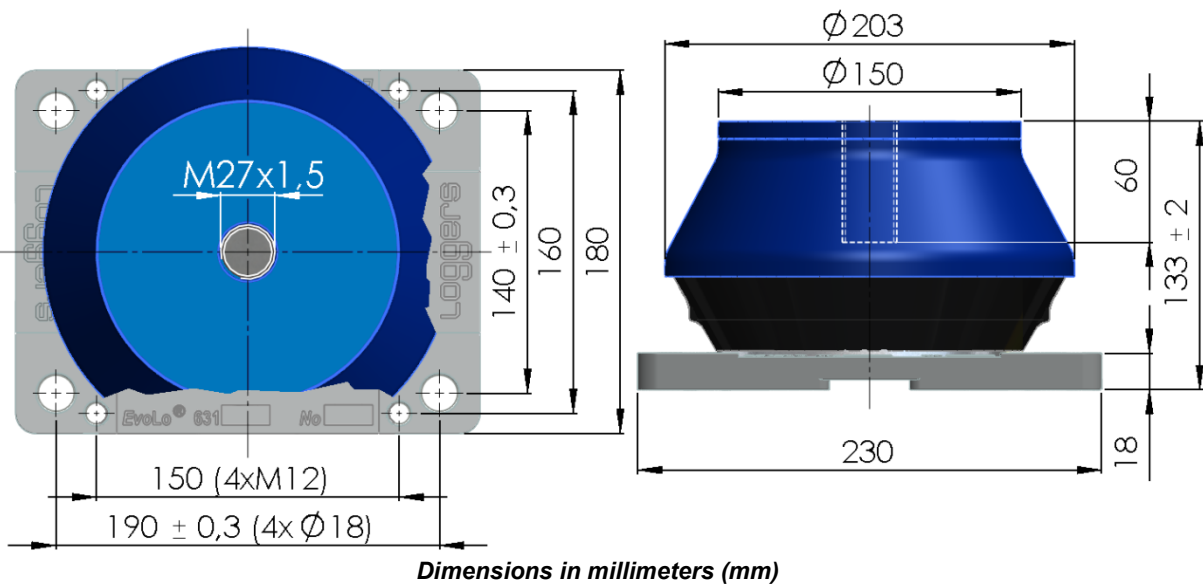

## MATERIAL

**Rubber part:** Highest quality natural rubber

**Metal:** Aluminum

## IDENTIFICATION

The type is marked in the mounting plate.

## ADVANTAGES

- ✓ Approved by: Lloyd's Register, DNV, BV (Bureau Veritas) and KRS
- ✓ Optimum vibration isolation
- ✓ Easy and quick installation
- ✓ Build in end-limiter to protect against overload
- ✓ Capable of handling both vertical and horizontal forces
- ✓ Natural rubber gives maximum vibration isolation
- ✓ One type fits all weights between 1000 and 6000 kg
- ✓ Stock item

## STATIC VERTICAL CHARACTERISTICS

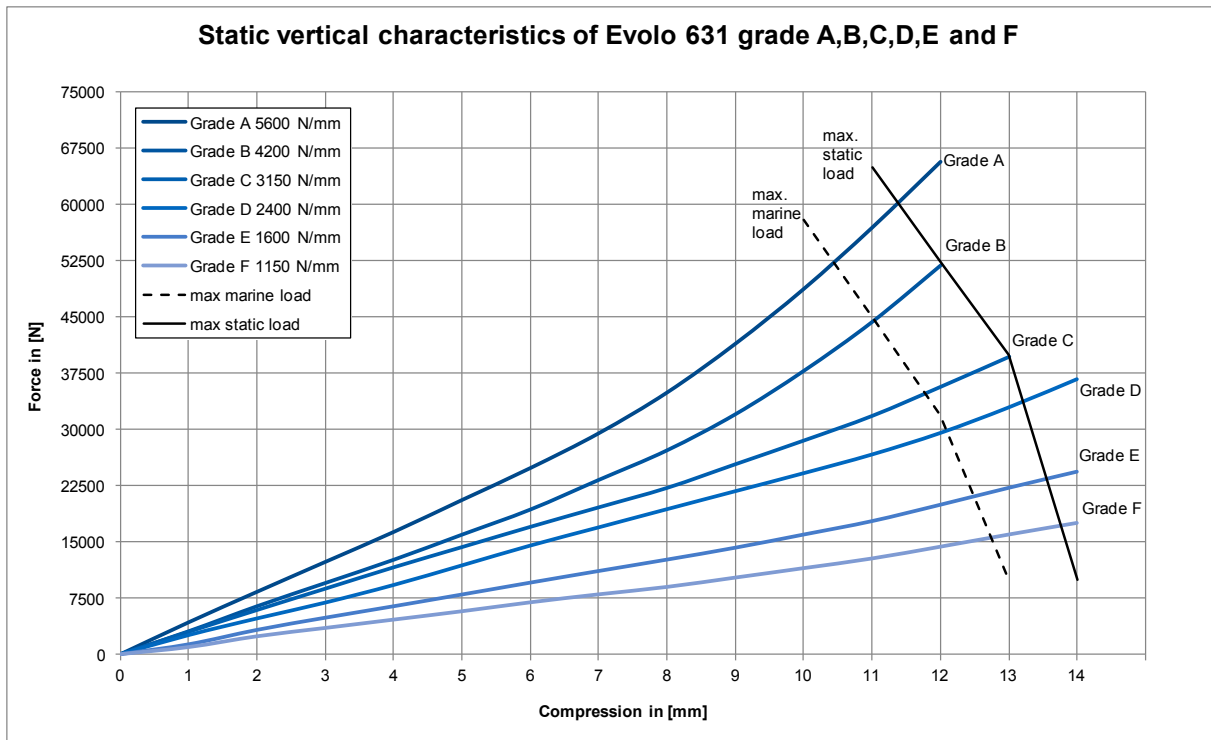

## HORIZONTAL CHARACTERISTICS WHEN PRECOMPRESSED 5 MM

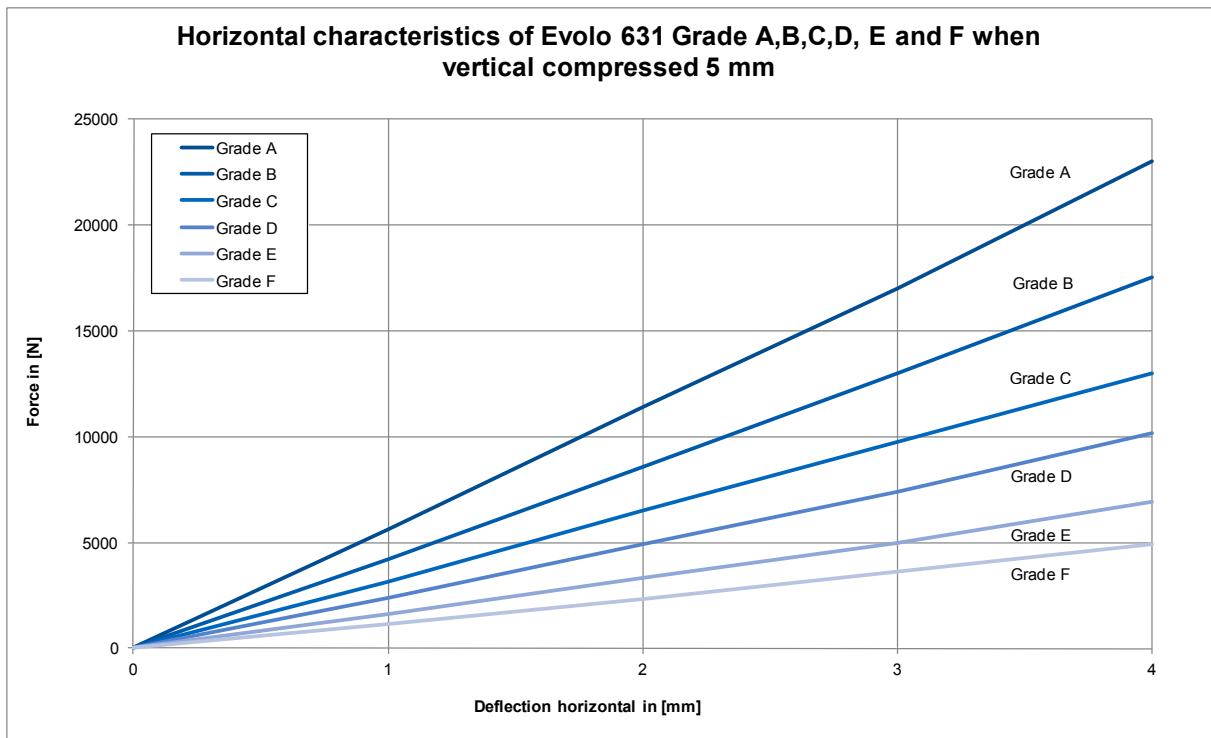

# ABOUT LOGGERS

Loggers is **thought leader** and international recognized solution provider in the field of shock, vibration and noise control. With **excellent technical know-how** in combination with proven market knowledge and experience Loggers designs, develops and engineers **innovative solutions** for the most complex and challenging situations for leading clients worldwide for over 90 years.

## Loggers understands all difficulties in the area of vibration, shock and noise control entirely.

We bring up the best and most cost effective solution for every challenge, regardless of its complexity. Loggers defines and engineers all deliverables necessary for solving your problem, ranging from standard to tailor-made solutions. Loggers' state-of-the-art portfolio contains all products and services to provide you with the optimal solution for relatively simple as well as the most complex challenges.

### Products

- Vibration mounts
- Expansion joints
- Shock mounts

### Services

- Assessment of current situation (on site)
- Analysis design including construction drawings
- Structural design and stress analysis
- Vibration measurement and analysis, if needed on site
- Solution definition based on:
  - standard products
  - customized products, or even
  - tailor-made new products, including prototyping
- Complete simulation of solution to ensure its effectiveness
- Testing including certification by independent certification authorities
- On site support during installation

Loggers understands both business and technology and brings both worlds together in satisfying customers' needs in rapidly changing environments. By working closely with clients Loggers enables them to realize their strategic targets through solving specific operational issues in the following market segments:

- Shipbuilding
- Dredging
- Defense
- Machinery
- Offshore
- Transportation



Version 03  
September 2011

### Loggers B.V.

Pieter Zeemanweg 133  
3316 GZ Dordrecht  
Mail: P.O. Box 194  
3300 AD Dordrecht  
The Netherlands  
Phone: +31 (0) 78 6182844  
Fax: +31 (0) 78 6180650  
sales@loggers.nl

### Loggers Schwingungstechnik GmbH

Am Markt 9  
D-27419 Sittensen  
Germany  
Phone: +49 (0) 4282/5949-0  
Fax: +49 (0) 4282/5949-39  
sales@loggers.de

